

Origin and evolution of the planktic foraminiferal Family Eoglobigerinidae Blow, 1979, during the early Danian (Paleocene)

Ignacio Arenillas* and José Antonio Arz

*Departamento de Ciencias de la Tierra (Paleontología) and Instituto Universitario de Investigación en Ciencias Ambientales de Aragón, Universidad de Zaragoza,
C/ Pedro Cerbuna 12, E-50009 Zaragoza, Spain.*

**ias@unizar.es*

RESUMEN

Nuevas evidencias sobre el origen y diversificación de la Familia Eoglobigerinidae Blow, 1979, o linaje reticulado-espinoso de foraminíferos planctónicos del Paleoceno, han sido identificadas en algunas de las secciones más continuas del Daniano inferior, principalmente en El Kef y Aïn Settara (Túnez). El descubrimiento de ejemplares transicionales sugiere una evolución desde el ancestral género Palaeoglobigerina Arenillas, Arz y Nájuez, 2007 (de pared lisa) hasta Eoglobigerina Morozova, 1959 (de pared reticulada), y desde éste último hasta los géneros Parasubbotina Olsson, Hemleben, Berggren y Liu, 1992 y Subbotina Brotzen y Pozaryska, 1961. La transición entre Palaeoglobigerina y Eoglobigerina implica cambios texturales progresivos en la superficie de la pared, tales como el desarrollo de poros en copa, espinas y finalmente pared reticulada. Este tránsito, sin embargo, implica cambios morfológicos externos pequeños entre la especie ancestral Palaeoglobigerina fodina (Blow, 1979) y la descendiente Eoglobigerina simplicissima (Blow, 1979), como son el incremento en el tamaño de la concha y del espesor del labio apertural.

Palabras clave: Paleoceno, textura de la pared, espinoso, eoglobigerínido, filogenia.

ABSTRACT

New evidence on the origin and diversification of the planktic foraminiferal Family Eoglobigerinidae Blow, 1979, or Paleocene spinose, cancellate lineage, has been discovered from some of the most continuous lower Danian sections known to date, especially from El Kef and Aïn Settara (Tunisia). Based on the discovery of transitional specimens, we suggest an evolution from primitive, smooth walled Palaeoglobigerina Arenillas, Arz and Nájuez, 2007, to cancellate Eoglobigerina Morozova, 1959, and then on to Parasubbotina Olsson, Hemleben, Berggren and Liu, 1992, and Subbotina Brotzen and Pozaryska, 1961. The transition from Palaeoglobigerina to Eoglobigerina implied progressive textural changes in the wall surface, such as the development of pore-pits, spines and eventually a cancellate wall. This transition, however, implied minor external morphologic changes between ancestral Palaeoglobigerina fodina (Blow, 1979) and its descendant Eoglobigerina simplicissima (Blow, 1979), such as the increase in test size and the thickness of the apertural lip.

Key words: Paleocene, wall texture, spinose, eoglobigerinid, phylogeny.

INTRODUCTION

The wall structure of the test of the earliest Danian planktic foraminifera underwent major changes after the Cretaceous/Paleogene (K/Pg) mass extinction event (Liu and Olsson, 1992, 1994). These changes resulted in the evolution of four wall textures among the trochospiral planktic foraminifera which became more or less stable during the early Danian: spinose cancellate wall (*Eoglobigerina* Morozova, 1959; *Subbotina* Brotzen and Pozaryska, 1961; and *Parasubbotina* Olsson, Hemleben, Berggren and Liu, 1992), nonspinose cancellate wall (*Praemurica* Olsson, Hemleben, Berggren and Liu, 1992), pitted-smooth wall (*Globanomalina* Haque, 1956), and pustulate wall (*Globoconusa* Khalilov, 1956). The spinose cancellate lineage is included in the Family Eoglobigerinidae Blow, 1979. The spinose wall indicates a carnivorous regime. Among the planktic foraminifera, this lineage was probably the first to occupy this niche in the earliest Paleocene (Olsson *et al.*, 1999). During the reproductive process (gametogenesis) the spines are dissolved, leaving holes in the empty spine, which are only visible with the help of a scanning electron microscope (SEM), if the preservation is good enough.

The origin of the spinose lineage during the earliest Danian is uncertain, although several phylogenetic hypotheses have been advanced. Olsson *et al.* (1992) and Liu and Olsson (1994) proposed that the “normal” perforate Danian planktic foraminifera (*i.e.*, pitted and cancellate walls) derived from *Hedbergella* Brönnimann and Brown, 1958. This hypothesis was already proposed by Berggren (1962, 1977), Olsson (1963, 1970) and Blow (1979). Olsson *et al.* (1992, 1999) suggested *H. monmouthensis* Olsson, 1960, as the predecessor of the spinose lineage. Apellániz *et al.* (2002) also suggested a hedbergellid origin for the spinose lineage but they considered *Hedbergella hillebrandti* Orue-Extebarria, 1985, as the ancestral form. In contrast to these, Arenillas and Arz (1996, 2000) and Arenillas *et al.* (2010) proposed that *Palaeoglobigerina* Arenillas, Arz and Nández, 2007, was the ancestor of *Eoglobigerina* and, therefore, of the spinose lineage.

In this paper, we have documented specimens with intermediary morphologically and texturally features from the smooth-walled *Palaeoglobigerina* to spinose cancellate walled *Eoglobigerina*, and from the latter to *Parasubbotina* and *Subbotina*. This study is based on high-resolution biostratigraphy and an intensive search for transitional specimens between species and genera in nine lower Danian sections of Europe, the Americas and North Africa, and in the Deep Sea Drilling Project Site 305 (Shatsky Rise, North Pacific).

MATERIAL AND METHODS

Because they are two of the most continuous and expanded lower Danian sections known to date (Molina *et al.* 2006, 2009), this work is focused especially on El Kef and

Aïn Settara sections (Tunisia). These sections allowed us to establish with precision the level of the first stratigraphical occurrences of studied species and genera. Figure 1 shows the biostratigraphic ranges of the studied taxa during the first 480 ky of the Paleocene, as well as the correlation of the zonations of Arenillas *et al.* (2004) and Berggren and Pearson (2005).

The zonation by Arenillas *et al.* (2004) includes six subzones: *Hedbergella holmdelensis* and *Parvularugoglobigerina longiapertura* Subzones of the *Guembelitra cretacea* Zone, the *Parvularugoglobigerina sabina* and *Eoglobigerina simplicissima* Subzones of the *Pv. eugubina* Zone, and the *Eoglobigerina trivialis* and *Subbotina triloculinoides* Subzones of the *P. pseudobulboides* Zone. As shown in Figure 1, the Zone P0 of Berggren and Pearson (2005) is equivalent to the *H. holmdelensis* Subzone, the Zone P α approximately spans both *P. longiapertura* Subzone and *Pv. eugubina* Zone, and P1a and P1b are roughly equivalent to *E. trivialis* and *S. triloculinoides* Subzones respectively. In order to study taxonomic details, we also have revised the fossil material from Elles (Tunisia), Ben Gurion (Israel), Caravaca and Agost (Spain), Bajada del Jagüel (Argentine), Lynn Creek (Mississippi) and Deep Sea Drilling Project Site 305 (Shatsky Rise, North Pacific). In addition, the biostratigraphic scheme proposed in Figure 1 takes also into account other relevant K/Pg sections, such as Gubbio (Italy), Zumaia (Spain), Bidart (France), El Mulato, El Mimbral, La Lajilla, Bochil and Guayal (Mexico), and Loma Capiro (Cuba). Geographical coordinates of all stratigraphic sections are given in Appendix 1.

All samples were disaggregated in water with diluted H₂O₂, and washed through a 63- μ m sieve. SEM-photographed specimens were mainly chosen from the El Kef and Aïn Settara sections. Although the diagenesis-induced recrystallization can be seen in many specimens of the Tunisian sections (“frosty” specimens according to the terminology of Sexton *et al.*, 2006), state of preservation is good enough to allow the analysis of the wall texture to be analyzed. Wall textures were examined under scanning electron microscopes JEOL JSM 6400 and Zeiss MERLIN FE-SEM at the Electron Microscopy Service of the Universidad de Zaragoza (Spain). Over 650 SEM-photographs, including different views and details of the surface of the tests of 180 specimens, were taken. Some of them are transitional morphotypes between two species. With the exception of the illustrations of type-specimens copied from the publications of other authors, all the specimens illustrated in Figures 2-9 are deposited in the Departamento de Ciencias de la Tierra of the Universidad de Zaragoza (Spain).

TAXONOMIC AND PHYLOGENETIC NOTES ON EOGLOBIGERINIDS AND RELATED GENERA

The classification used for the eoglobigerinids and their ancestral forms as recognized in this paper is mainly based

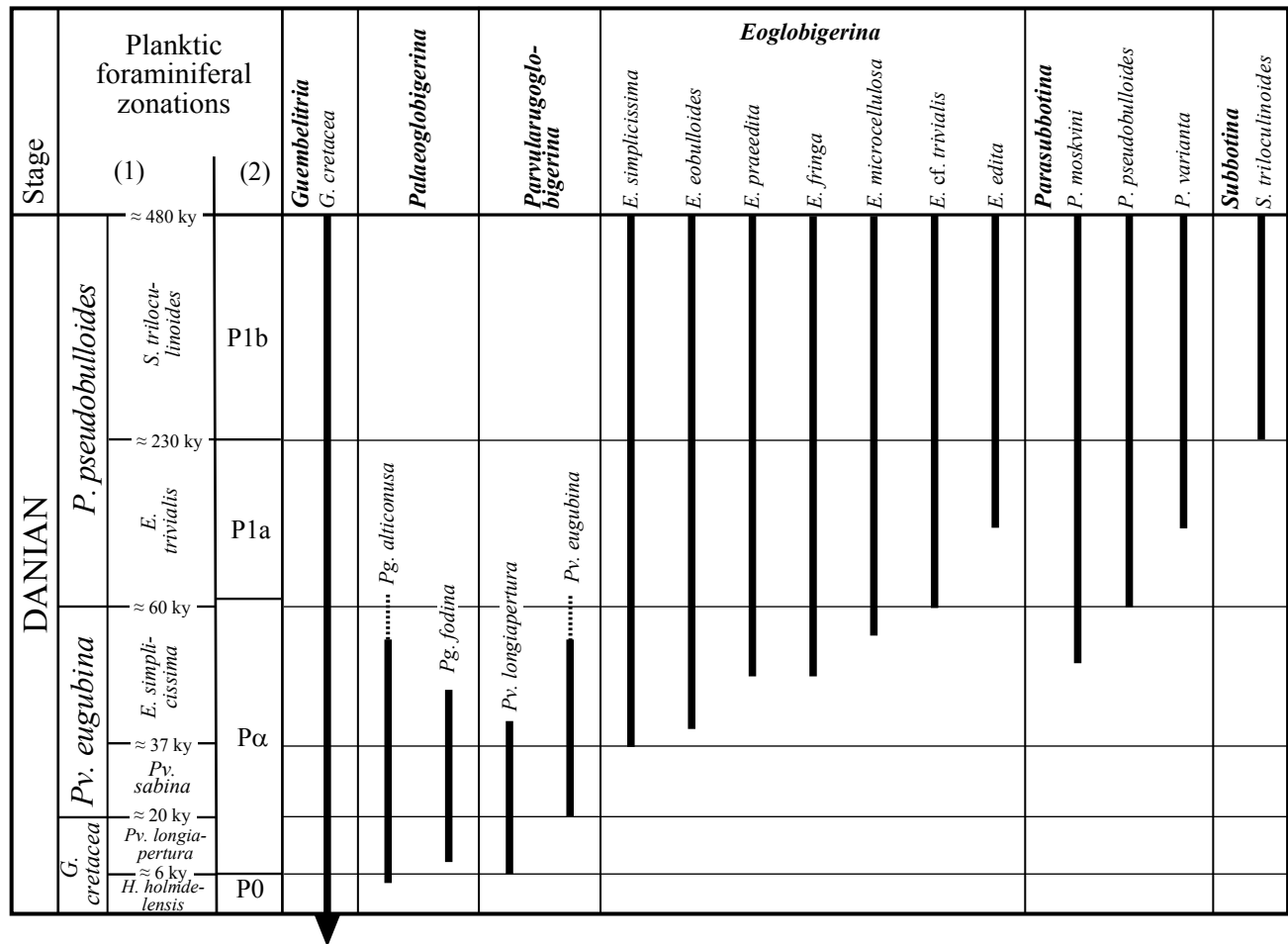

Figure 1. Biostratigraphic ranges of the analyzed species: (1) planktic foraminiferal zonation after Arenillas *et al.* (2004), and (2) planktic foraminiferal zonation after Berggren and Pearson (2005); dotted lines indicate uncertain biostratigraphic range (not supported by SEM-photographed specimens).

on those by Blow (1979), Toumarkine and Luterbacher (1985), Olsson *et al.* (1992) and Arenillas (1996), with some modifications and updates of Olsson *et al.* (1999) and Arenillas *et al.* (2007). The following species were analyzed: *Palaeoglobigerina alticomusa* (Li, McGowran and Boersma, 1995; Figures 2.1-2.2), *Pg. fodina* (Blow, 1979; Figures 2.3-2.5), *Eoglobigerina simplicissima* Blow, 1979 (Figures 2.6-2.9), *E. eobulloides* Morozova (1959; Figures 2.10-2.13), *E. praeedita* Blow (1979; Figures 2.14-2.16), *E. edita* (Subbotina, 1953; Figures 2.17-2.20), *E. cf. trivialis* (*E. trivialis* Subbotina, 1953, *sensu* Blow, 1979; Figures 3.1-3.7), *E. microcellulosa* (Morozova, 1961; Figures 3.8-3.10), *E. fringa* (Subbotina, 1950; Figures 4.1-4.3), *Subbotina triloculinoides* (Plummer, 1927; Figures 3.11-3.15), *Parasubbotina moskvini* (Shutskaya, 1953; Figures 4.4-4.6), *P. varianta* (Subbotina, 1953; Figures 4.7-4.9) and *P. pseudobulloides* (Plummer, 1927; Figures 4.10-4.12). Apellániz *et al.* (2002) used a similar taxonomic scheme for the eoglobigerinids. Diagnostic characteristics of all these species are presented in Appendix 2. Details of the wall surface of selected species are illustrated in Figures 5-9.

The discrimination of these species is not supported by morpho- or ecostatistical analyses, therefore some of them can be synonyms. Nevertheless, we retain this classification to analyse better the relationships between taxa, since some of them are intermediate forms between three to four-chambered *Eoglobigerina* and four to six-chambered *Eoglobigerina* (e.g., *E. eobulloides*), between *Eoglobigerina* and *Parasubbotina* (e.g., *E. fringa*), and between *Eoglobigerina* and *Subbotina* (e.g., *E. microcellulosa*). *Parasubbotina moskvini* was not considered by either Olsson *et al.* (1999) nor Apellániz *et al.* (2002), and most probably they included it in *P. varianta*. Others assigned it to *P. pseudobulloides* (e.g., Stainforth *et al.*, 1975; Blow, 1979; Toumarkine and Luterbacher, 1985). Arenillas (1996) restricted the name “*varianta*” to morphotypes with four chambers in the last whorl and a high rate of chamber size increase, and “*pseudobulloides*” to morphotypes with more than four chambers (usually between 4 ½ to 5 chambers), and retained the name “*moskvini*” for morphotypes that also have four chambers in the last whorl as “*varianta*” but only a moderate to low rate of increase in chamber size.

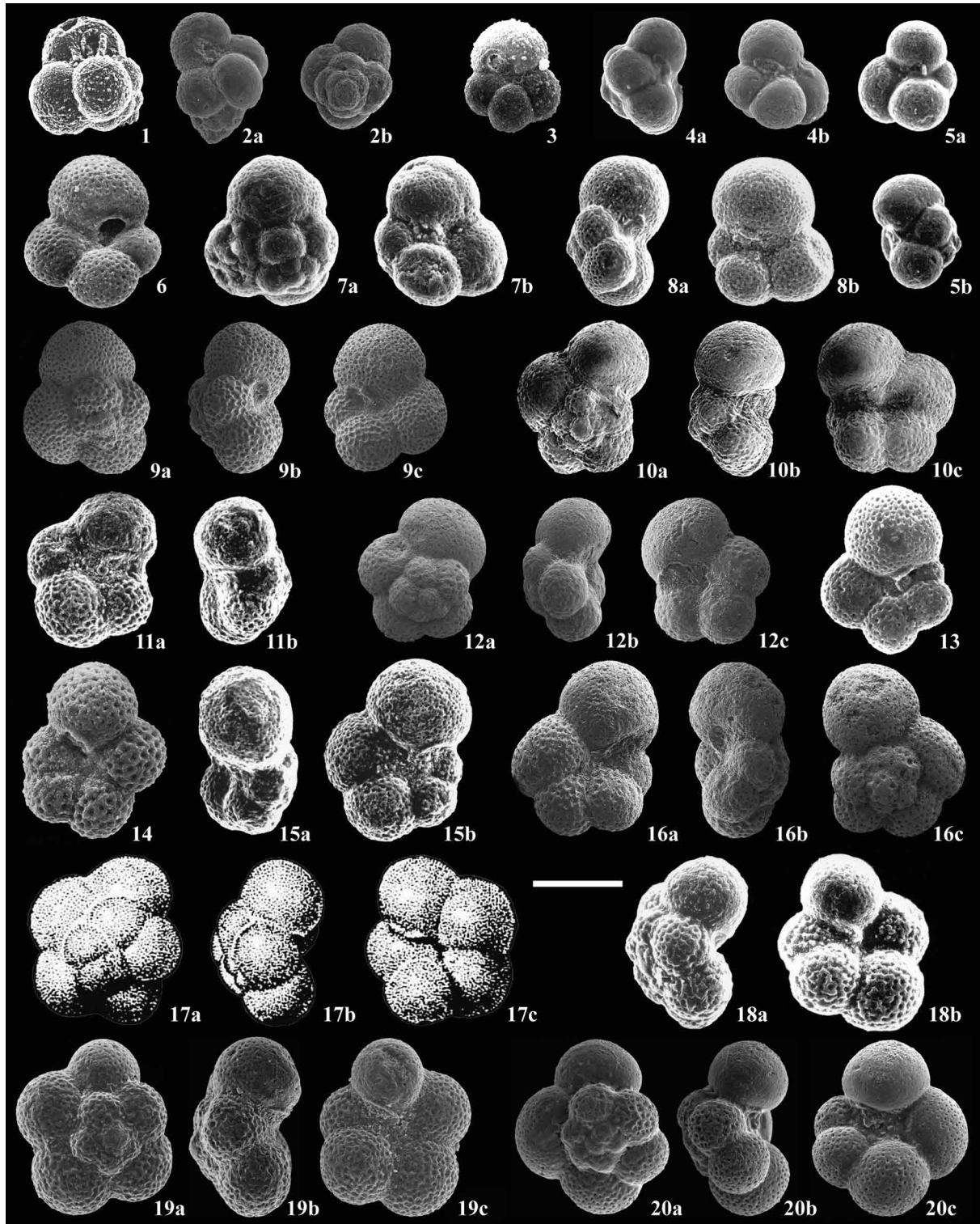

Figure 2. SEM images of *Palaeoglobigerina* Arenillas, Arz and Nález (2007), and *Eoglobigerina* Morozova (1959) species (scale bar = 100 μ m). 1-2. *Palaeoglobigerina alticonusa* (Li, McGowran and Boersma, 1995): 1, holotype from Zone P α , DSDP Site 152, Caribbean Pacific (from Li *et al.*, 1995, pl. 2, fig. 9); 2, specimen from the *E. simplicissima* Subzone, El Kef, Tunisia. 3-5. *Palaeoglobigerina fodina* (Blow, 1979): 3, holotype from Zone P α , DSDP Leg 6, South Pacific (from Blow, 1979, pl. 57, figs. 5-6); 4, specimen from the *Pv. longiapertura* Subzone, Ain Settara, Tunisia; 5, specimen from the *Pv. longiapertura* Subzone, El Kef, Tunisia. 6-9. *Eoglobigerina simplicissima* Blow (1979): 6, holotype from Zone P α , lowermost Danian, from DSDP Leg 6, South Pacific (from Blow, 1979, pl. 55, fig. 1); 7, specimen from the *S. triloculinoides* Subzone, Agost, Spain; 8, specimen from the *E. trivialis* Subzone, Ain Settara, Tunisia; 9, specimen from the *E. simplicissima* Subzone, Ain Settara, Tunisia. 10-13. *Eoglobigerina eobulloides* Morozova (1959): 10, holotype from lower Danian sediments, Tarkhankhut Peninsula, Crimea, Ukraine (from Olsson *et al.*, 1999, pl. 8, figs. 10-12); 11, specimen from the *G. compressa* Zone, Caravaca, Spain; 12, specimen from the *E. simplicissima* Subzone, Ain Settara, Tunisia; *continues*

The Family Eoglobigerinidae was defined by Blow (1979) for the Paleogene globigerinids with trochospiral coil, an essentially intraumbilical (or asymmetrically umbilical) aperture with a porticus (*i.e.*, thick lips), and cancellate wall texture (*i.e.*, pore-pits and associated interpore ridges). Initially he included the genera *Eoglobigerina*, *Subbotina*, and *Globastica* Blow, 1979 in this family, and considered the first two genera to be phylogenetically related, whilst the third collaterally related to *Eoglobigerina*. He also suggested that genera *Eoglobigerina* and *Globastica* contain taxa probably derived paedomorphically from Cretaceous rugoglobigerinid ancestors. Contrary to the opinion of Blow (1979), *Globastica* is now widely considered to be a junior synonym of *Globoconusa* Khalilov, 1956 (Olsson *et al.*, 1999). Moreover, *Globoconusa* (= *Globastica*) must be excluded from the Family Eoglobigerinidae as its wall texture is more closely related to the Family Guembeltriidae Montanaro-Gallitelli (1957), as proposed Olsson *et al.* (1999).

Loeblich and Tappan (1987) emended the Family Eoglobigerinidae, suggesting its member to have a non-spinose smooth or pitted wall instead of cancellate wall. They included the smooth-walled genus *Parvularugoglobigerina* Hofker (1978) and excluded the genus *Subbotina*, which was reassigned to the Family Catapsydracidae Bolli, Loeblich and Tappan, 1957. Olsson *et al.* (1992, 1999) re-included *Eoglobigerina* and *Subbotina* in the Family Globigerinidae Carpenter, Parker and Jones, 1862, where it had been placed traditionally (*Subbotina*, 1953; Bolli, 1957; Berggren, 1977), and added their recently defined genus *Parasubbotina* to the same family. Furthermore, they moved *Parvularugoglobigerina* to the Family Guembeltriidae because of the close relationships between parvularugoglobigerinids and guembeltrids.

The species of the genus *Palaeoglobigerina* are usually grouped in *Parvularugoglobigerina*, as both genera have an identical wall texture (Arenillas *et al.*, 2007, 2010). They exhibit a smooth wall texture with tiny pore-murals (< 1 µm in diameter). Arenillas *et al.* (2007) separated *Palaeoglobigerina*, whose type-species is *Pg. fodina* (Blow 1979; Figures 2.1-2.3), from *Parvularugoglobigerina*, whose type-species is *Pv. eugubina* (Luterbacher and Premoli-Silva, 1964), to comprise species previously classified as primitive *Eoglobigerina* or *Globoconusa* (Blow, 1979; Canudo *et al.*, 1991; Keller, 1988; Keller *et al.*, 1995; Arenillas and Arz, 1996, 2000). *Palaeoglobigerina* differs from *Parvularugoglobigerina* by its smaller number of chambers, both in the first spire whorl (3 ½ - 4 instead of 4 - 4 ½) and in the last one (3 - 4 instead of 4 - 9). However,

both genera are closely related, are included into an informal “parvularugoglobigerinid” group, and seem appropriate to be classified within the Family Guembeltriidae (Olsson *et al.*, 1999). The inclusion of parvularugoglobigerinids such as *Palaeoglobigerina* in the Family Eoglobigerinidae, as done by Loeblich and Tappan (1957) and Apellániz *et al.* (2002), is debatable because they present sharply different wall texture.

Arenillas *et al.* (2012) have recently revealed the occurrence of two groups of primitive trochospiral species with different wall textures and stratigraphic ranges in the earliest Danian. The first group, whose species were attributed to parvularugoglobigerinids, exhibits a smooth wall texture (with pore-murals) and evolved in the proximity of the P0-Pα transition. The second group, assigned to the new genus *Trochoguembeltria* Arenillas, Arz and Nájuez, 2012, has a rugose wall texture (with rugosities and irregular pore-mounds) and evolved in the proximity of the Pα-P1 transition. Textural and biostratigraphic data suggest that this group is a lineage different from that of the parvularugoglobigerinids. Trochospiral specimens with rugose or pore-mounded wall were already documented by Liu and Olsson (1992, 1994), and Olsson *et al.* (1992, 1999), but they considered them as belonging to *Guembeltria*?, or to *Parvularugoglobigerina* after emending the genus. It is important to consider this aspect because the smooth wall type attributed to parvularugoglobigerinids should not be misinterpreted as a product of poor preservation in the tunisian sections, since specimens with smooth wall and others with more ornamented walls (*i.e.*, pore-mounded *Guembeltria*, and/or rugose *Woodringina*) co-occur in the samples from the P0-Pα transitional interval similarly affected by the diagenesis process (Arenillas *et al.*, 2010, 2012).

Eoglobigerina, whose type-species is *E. eobulloides*, was initially defined as a subgenus of *Globigerina* and described as Danian globigeriniforms with a thin and smooth wall (Morozova, 1959). Blow (1979) emended *Eoglobigerina*, elevating it to generic rank and re-describing it to have a cancellate wall texture (pore-pits usually with clearly defined interpore ridges), intraumbilical aperture with a weakly developed porticus (*i.e.*, thick lip). He also suggested that it represents a primitive group ancestral to *Subbotina* Brotzen and Pozaryska, 1961. Blow (1979) tentatively included some earliest Danian species with smooth wall in *Eoglobigerina*?, such as *E.?* *fodina* (Blow, 1979) or *E.?* *extensa* (Blow, 1979), reassigned later to *Palaeoglobigerina* by Arenillas, Arz and Nájuez (2007). Hemleben *et al.* (1991) demonstrated that *Eoglobigerina*

Figure 2 (continued). 13. specimen transitional to *E. praedita* from the Zone Pα, DSDP Leg 6, South Pacific. 14-16. *Eoglobigerina praedita* Blow (1979): 14, holotype from Zone Pα, DSDP Leg 6, South Pacific (from Blow, 1979, pl. 55, fig. 6); 15, specimen from the *G. compressa* Zone, Caravaca, Spain; 16, specimen from the *E. simplicissima* Subzone, Ain Settara, Tunisia. 17-20. *Eoglobigerina edita* (Subbotina, 1953): 17, holotype from Zone Pα, Kuban River, Northern Caucasus, Russia (from Blow, 1979, pl. 2, fig. 1a-c); 18, specimen from the *A. trinidadensis* Zone (middle Danian), Agost, Spain; 19, specimen from the *S. trilocolinoides* Subzone, Gurion, Israel; 20, specimen from the *S. trilocolinoides* Subzone, El Kef, Tunisia.

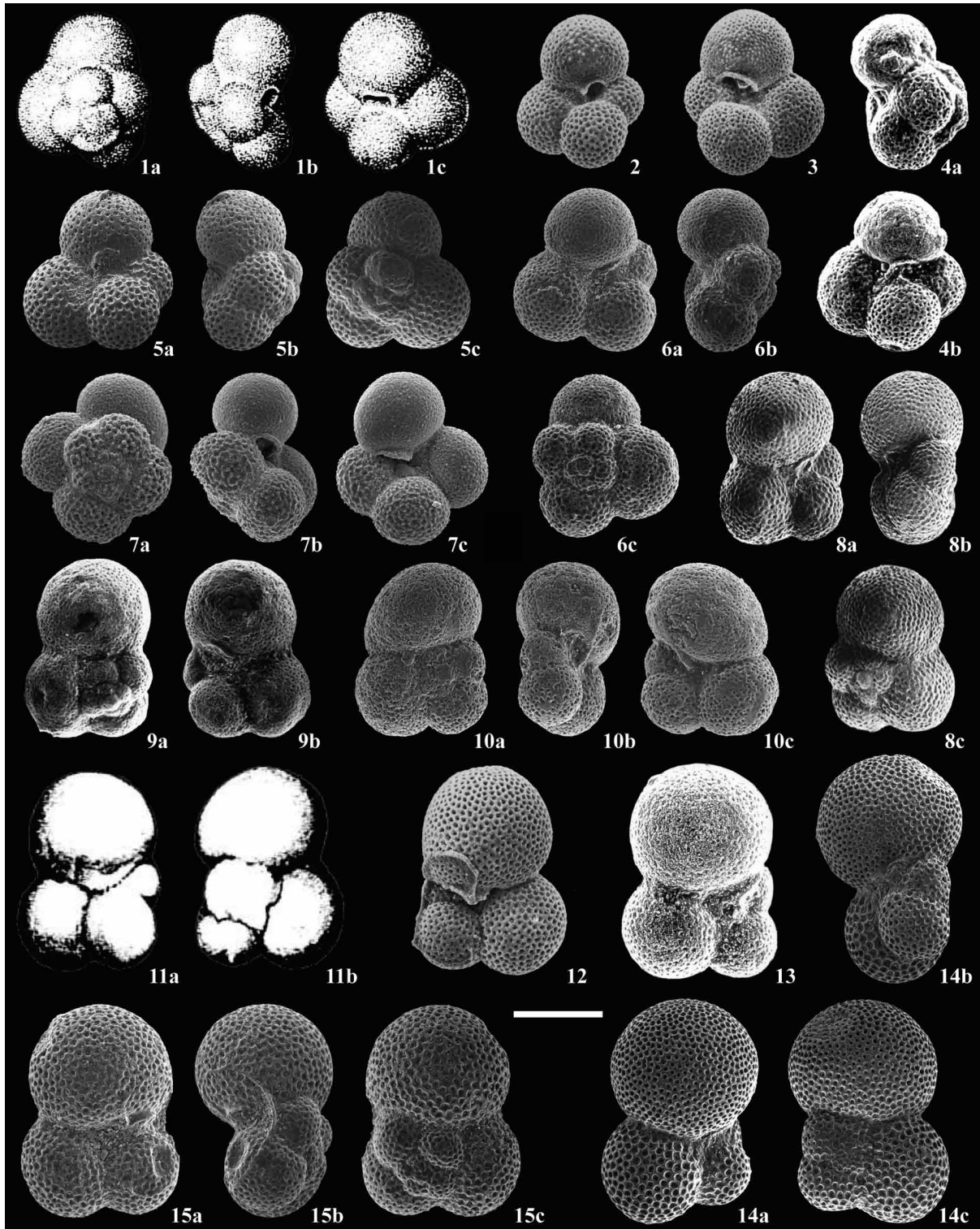

Figure 3. SEM images of *Eoglobigerina* and *Subbotina* species (scale bar = 100 μ m). 1-7. *Eoglobigerina* cf. *trivialis* = *Eoglobigerina trivialis* (Subbotina, 1953), *sensu* Blow (1979): 1, paratype from the Danian sediments, Kuban River, Northern Caucasus, Russia (from Subbotina, 1953, pl. 4, fig. 6a-c); 2, hypotype from Blow (1979) from the Zone P1, DSDP Leg 6, South Pacific (from Blow, 1979, pl. 73, fig. 3); 3, hypotype from Blow (1979) from Zone P1, DSDP Leg 6, South Pacific (from Blow, 1979, pl. 73, fig. 5); 4, specimen from the *S. triloculinoides* Subzone, El Kef, Tunisia; 5, specimen from the *G. compressa* Zone, Caravaca, Spain; 6, specimen from the *S. triloculinoides* Subzone, Ben Gurion, Israel; 7, specimen from Danian, DSDP Site 305, Shatsky Rise, North Pacific. 8-10. *Eoglobigerina microcellulosa* (Morozova, 1961): 8, holotype from the lower Danian sediments, Tarkhankhut Peninsula, Crimea, Ukraine (from Olsson *et al.*, 1999, pl. 9, figs. 13-15); 9, specimen from the *G. compressa* Zone, Caravaca, Spain; 10, *E. microcellulosa*, specimen from the *E. simplicissima* Subzone, El Kef, Tunisia. 11-15. *Subbotina triloculinoides* (Plummer, 1927): 11, holotype from the Danian sediments, Station 23, *continues*

has a spinose texture, which clearly separates it from the other cancellate taxa such as *Praemurica*. For this reason, Olsson *et al.* (1999) emended the genus to include the spinose character.

Parasubbotina, whose type-species is *P. pseudobulloides*, was defined to group low trochospiral, spinose-cancellate globigeriniforms of the Danian (Olsson *et al.*, 1992). Its aperture was described as umbilical-extraumbilical and bordered by a narrow lip. As in other eoglobigerinids, the degree of development of the cancellate wall varies from one specimen to another, probably depending on the paleoenvironmental conditions. These species, mainly *P. moskvini* and *P. pseudobulloides*, display a weakly developed cancellate wall in the transition between the *Pv. eugubina* and the *P. pseudobulloides* Zones. Therefore, it is often difficult to recognize the first occurrence of both species, and consequently the base of the *P. pseudobulloides* Zone. For this reason, Olsson *et al.* (1992, 1999) proposed the species *Parasubbotina* aff. *pseudobulloides* to comprise such small primitive morphotypes.

Subbotina, whose type-species is *S. triloculinoides*, was initially defined as globigeriniforms with intraumbilical to umbilical-extraumbilical aperture, and wall texture with pore-pits and pillars (Brotzen and Pozaryska, 1961). Jenkins (1971) and Blow (1979) emended the definition of the genus based on a more complete description of its morphology and texture, and indicated that *Subbotina* presents variably developed cancellate wall, strongly inflated chambers -increasing rapidly in size-, and an asymmetrical umbilical-extraumbilical aperture bordered by a thick lip. Loeblich and Tappan (1987) considered *Eoglobigerina* to be a junior synonym of *Subbotina*. Olsson *et al.* (1992) demonstrated that *Subbotina* has a spinose ornamentation, and Olsson *et al.* (1999) emended the genus to include this feature. Loeblich and Tappan (1987) considered *Eoglobigerina* to be a junior synonym of *Subbotina*. However, others have retained both generic names and considered *Subbotina* and *Eoglobigerina* as separate genera (e.g. Arenillas, 1996; Olsson *et al.*, 1999). Usually species of the genus *Subbotina* have "tripartite" test (*i.e.*, 3 - 3 ½ chambers in the last whorl) with a moderate to high rate of chamber size increase. The second displays 3 ½ - 7 chambers in the last whorl with a low rate of increase in chamber size. In addition, the trochospire is usually lower in *Subbotina* than in *Eoglobigerina*.

DISCUSSION

According to Arenillas *et al.* (2007) the first species to evolve of *Eoglobigerina*, *Parasubbotina* and *Subbotina*

were *E. simplicissima*, *P. moskvini* and *S. triloculinoides* respectively. Intermediate specimens between these taxa have been found mainly in lowermost Danian samples of El Kef and Ain Settara. Figures 5-9 illustrate details of the wall surface of some of these specimens, which suggest an evolution of the wall texture as proposed in Figure 10.

Some of the SEM-photographed specimens display characteristics transitional between *Pg. fodina* and *E. simplicissima* (Figures 5.4-5.5; Figures 6.1-6.2). The external morphology of both species is very similar, differing mainly in the shape of the aperture, the thickness of the lip and the test size. Typical *Pg. fodina* exhibits a highly arched aperture with a thin lip, although the apertural arch is lower and the lip is thicker in some more modern specimens (*e.g.*, Figures 2.5). In contrast, the test of *E. simplicissima* is larger and the aperture is a low arch usually with thick lips. The most significant difference between the two species is the wall texture: the first one presents smooth wall, and the second one, pitted or cancellate wall.

The transition from *Palaeoglobigerina* to *Eoglobigerina* seems to have implied the following evolutionary changes: (1) increase in test size; (2) increase in pore size; (3) increase in lip thickness; (4) evolution from tiny pore-murals to large pore-pits; (5) development of spines; and (6) evolution from smooth to cancellate wall. The increase in test size and pore size started within the genus *Palaeoglobigerina* (Figures 5.1-5.3), as exemplified in Figures 10a and 10b. The more primitive specimens of *E. simplicissima* (Figures 6.4-6.5) are only slightly larger than their ancestor *Pg. fodina*. However, they are assigned to *E. simplicissima* because they have incipient pore-pits and thicker lips. The wall texture of these first *Eoglobigerina* specimens may best be described as pitted (as in Figures 10c, 10d and 10e) rather than as cancellate. Distinct spine holes in these specimens were not visible, but some small holes may be identified in test surface of slightly more modern specimens of *E. simplicissima* and they could be vacated spine holes (Figures 6.1-6.2). The development of spines seems to have occurred later than the pore-pits, but prior to the development of the cancellate wall as suggested in the diagrams shown in Figures 10e and 10f.

This hypothesis on the origin of the eoglobigerinids, or spinose lineage, differs from those by Olsson *et al.* (1992, 1999) and Apellániz *et al.* (2002) who suggested an early "hedbergellid" origin, occurring shortly after the K/Pg boundary, *i.e.*, within the Zone P0 or *H. holmdelensis* Subzone. Olsson *et al.* (1999) suggested major changes in wall texture and test morphology in the transition from the pustulose, pitted *H. monmouthensis* to the spinose, cancellate *Eoglobigerina* and *Parasubbotina* taking place

Figure 3 (continued). Midway Group, Navarro County, Texas (from Plummer, 1927, pl. 8, figs. 10a-b); 12, hypotype from Blow (1979) from the Zone P1, DSDP Leg 6, South Pacific; 13, specimen from the *S. triloculinoides* Subzone, Ain Settara, Tunisia; 14, specimen from the *M. pusilla* Zone (Danian-Selandian transition), Gebel Aweina, Egypt; 15, specimen from the *S. triloculinoides* Subzone, Ben Gurion, Israel.

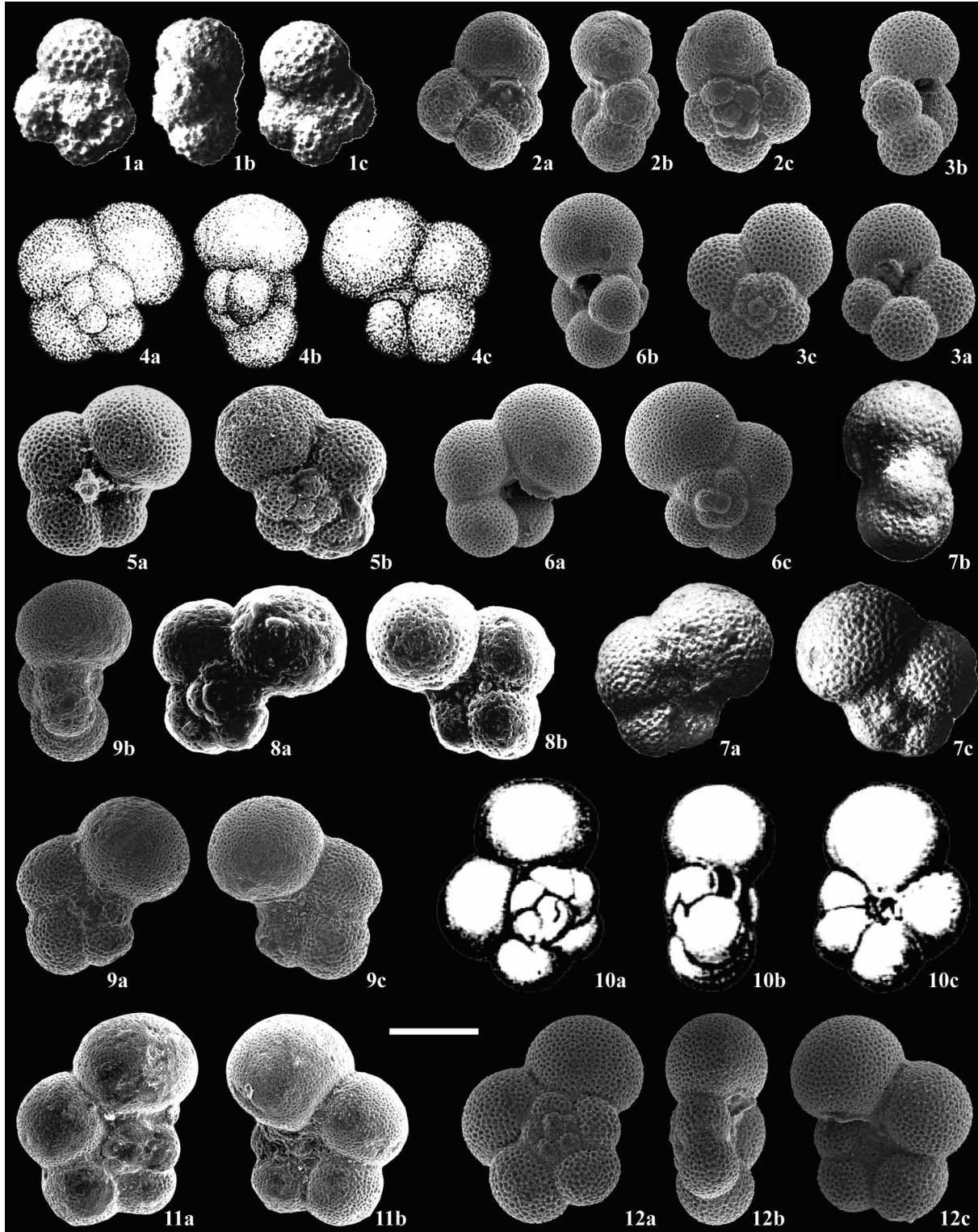

Figure 4. SEM images of *Eoglobigerina* and *Parasubbotina* species (scale bar = 100 μ m). 1-3. *Eoglobigerina fringa* (Subbotina, 1950): 1, holotype from Danian, Mineralovodsk, northwestern Caucasus, Russia (from Olsson *et al.*, 1999, pl. 9, figs. 7-9); 2, specimen from the *S. trilocolinoides* Subzone, El Kef, Tunisia; 3, specimen from Danian, DSDP Site 305, Shatsky Rise, North Pacific. 4-6. *Parasubbotina moskvini* (Shutskaya, 1953): 4, holotype from Danian, Kheu River, Northern Caucasus, Russia (from Shutskaya, 1953, pl. 1, figs. 1-3); 5, specimen from the *E. trivialis* Subzone, Aïn Settara, Tunisia; 6, *P. moskvini*, specimen from Danian, DSDP Site 305, Shatsky Rise, North Pacific. 7-9. *Parasubbotina varianta* (Subbotina, 1953): 7, holotype from Danian, Kuban River, Northern Caucasus, Russia (from Olsson *et al.*, 1999, pl. 9, figs. 16-18); 8, specimen from the *S. trilocolinoides* Subzone, Agost, Spain; 9, specimen from the *S. trilocolinoides* Subzone, Ben Gurion, Israel. 10-12. *Parasubbotina pseudobulloides* (Plummer, 1927): 10, holotype from Danian, Wills Point Fm., Midway Group, Navarro County, Texas (from Plummer, 1927, pl. 8, figs. 9a-c); 11, specimen from the *S. trilocolinoides* Subzone, Aïn Settara, Tunisia; 12, specimen from the lower Danian, DSDP Site 305, Shatsky Rise, North Pacific.

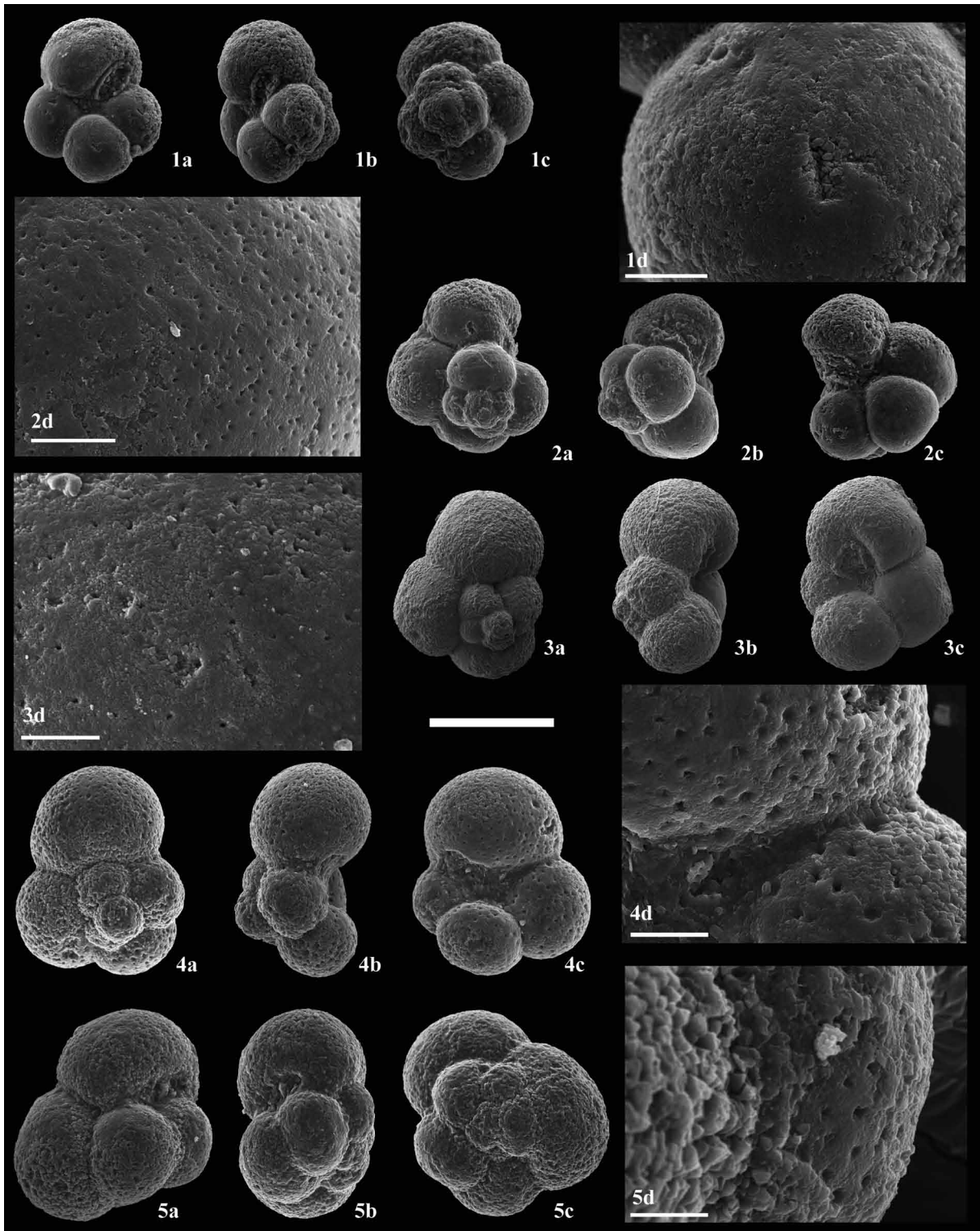

Figure 5. SEM images of *Palaeoglobigerina fodina* and *Eoglobigerina simplicissima* specimens and details of their smooth wall texture (scale bar = 100 μm ; scale bar of wall details = 10 μm). 1-3. *Palaeoglobigerina fodina* (Blow, 1979): 1, specimen from the *Pv. longiapertura* Subzone, El Kef, Tunisia; 2, specimen from the *Pv. longiapertura* Subzone, El Kef, Tunisia; 3, specimen from the *E. simplicissima* Subzone, Ain Settara, Tunisia. 4-5. *Eoglobigerina simplicissima* Blow (1979): 4, specimen intermediate to *Pg. fodina* from the *E. simplicissima* Subzone, El Kef, Tunisia; 5, specimen intermediate to *Pg. fodina* (Blow, 1979), from the *E. simplicissima* Subzone, El Kef, Tunisia.

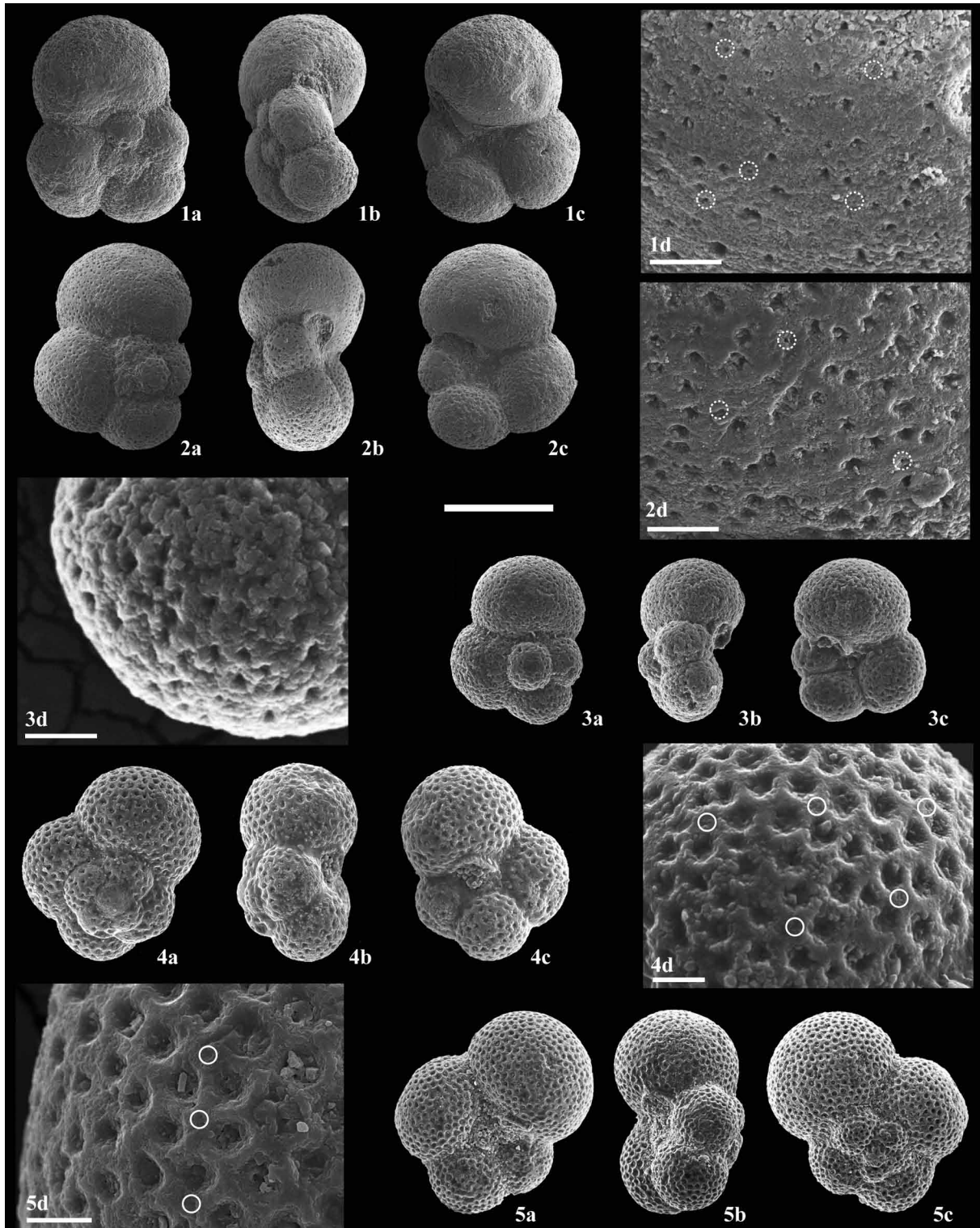

Figure 6. SEM images of *Eoglobigerina simplicissima* and *Eoglobigerina fringa* specimens and details of their smooth wall texture (scale bar = 100 μm ; scale bar of wall details = 10 μm). 1-3. *Eoglobigerina simplicissima* Blow (1979): 1, specimen intermediate to *Pg. fodina*, from the *E. simplicissima* Subzone, El Kef, Tunisia; 2, specimen intermediate to *Pg. fodina*, from the *E. simplicissima* Subzone, El Kef, Tunisia; 3, juvenil specimen from the *E. simplicissima* Subzone, El Kef, Tunisia. 4-5. *Eoglobigerina fringa* (Subbotina, 1950): 4, specimen intermediate to *E. simplicissima*, from the *E. simplicissima* Subzone, El Kef, Tunisia; 5, specimen from the *S. triloculinooides* Subzone, Ben Gurion, Israel. Dashed circles mark possible spine holes and solid circles probable or certain spine holes.

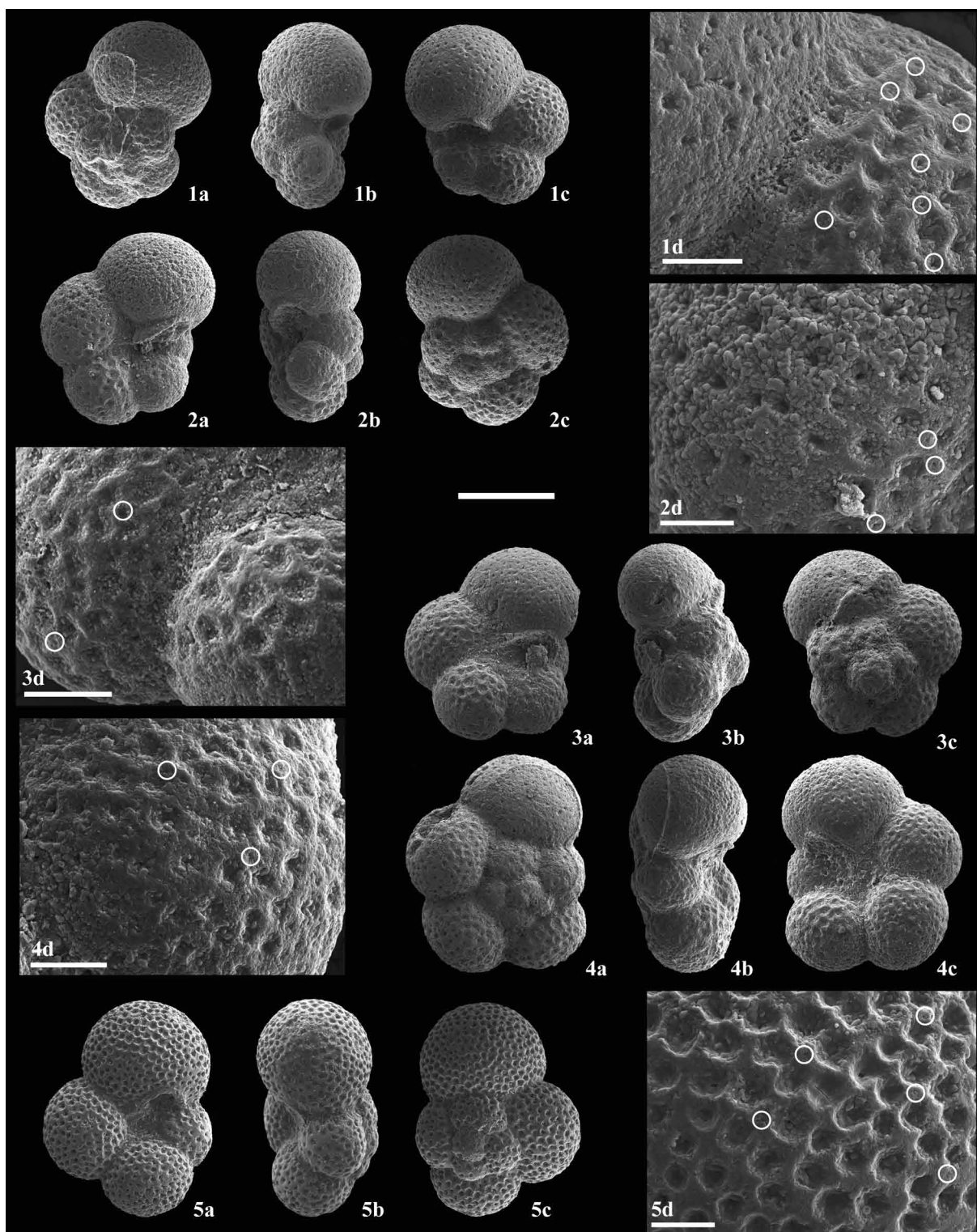

Figure 7. SEM images of *Eoglobigerina eobulloides*, *Eoglobigerina praedita* and *Eoglobigerina simplicissima* specimens and details of their smooth wall texture (scale bar = 100 μm ; scale bar of wall details = 10 μm). 1-3. *Eoglobigerina eobulloides* Morozova (1959): 1, specimen intermediate to *Eoglobigerina simplicissima* (Blow, 1979), from *E. simplicissima* Subzone, Ain Settara, Tunisia; 2, specimen from the *E. simplicissima* Subzone, Ain Settara, Tunisia; 3, specimen transitional to *E. praedita*, from the *E. simplicissima* Subzone, Ain Settara, Tunisia. 4. *Eoglobigerina praedita* Blow (1979), specimen from the *E. simplicissima* Subzone, Ain Settara, Tunisia. 5. *E. simplicissima*, specimen transitional to *Eoglobigerina cf. trivialis*, from the *E. trivialis* Subzone, El Kef, Tunisia. Solid circles mark probable or certain spine holes.

in a relatively short time on a geological and evolutionary time scale. However, we did not find single cancellate specimen assignable to the eoglobigerinids in the Zone P0 at the most continuous K/Pg sections known to date (Arenillas *et al.*, 2000a,b). The Zone P0 was originally defined as the interval between the K/Pg boundary mass extinction and the first occurrence of Danian species (Smit, 1982), *i.e.*, from the last occurrence of upper Maastrichtian *Abathomphalus mayaroensis* (Bolli, 1951) to the first occurrence of *Pg. alticonusa* and/or *Pv. longiapertura* (= *Pv. eugubina* for other authors). As noted by Arenillas *et al.* (2004), this original definition of the Zone P0 seems to exclude the occurrence of the eoglobigerinids within it. According to our biostratigraphic data (Figure 1), eoglobigerinids appeared at the time equivalent to the base of the *E. simplicissima* Subzone (or middle part of Zone P α). Biostratigraphic and textural data suggest that the evolutionary transition from *Palaeoglobigerina* to *Eoglobigerina* is more consistent with our data than the postulated transition from *Hedbergella* to *Eoglobigerina*. This scenario involves a smaller number of morphological and textural changes, and is more compatible with the planktic foraminiferal assemblages identified in the Zone P0 and the lower part of Zone P α , where only triserial and biserial guembeltriids and smooth walled parvularugoglobigerinids were identified (Luterbacher and Premoli Silva, 1964; Smit, 1982; Toumarkine and Luterbacher, 1985; Arenillas and Arz, 2000; Arenillas *et al.*, 2007, 2010).

The very weakly developed cancellate wall (pitted wall) in the earliest representatives of the genus *Eoglobigerina*, within the *E. simplicissima* Subzone and the lower part of *P. pseudobulloides* Zone, contrasts with the strongly developed cancellate wall of the most modern specimens. Some examples of specimens with pitted wall are illustrated, *e.g.*, *E. simplicissima* (Figures 6.1-6.2) and *P. moskvini* (Figure 8.3). Olsson *et al.* (1992, 1999) included these latter morphotypes in *P. aff. pseudobulloides*, and their wall texture resembles that of the pitted smooth wall of the genus *Globanomalina*. However, all *eoglobigerinids*, except perhaps in the earliest specimens of *E. simplicissima* mentioned above, have already a more or less developed spinose wall texture. In almost all species, the thickness of the lips increases gradually and it resembles a porticus in some specimens of *Parasubbotina* (*e.g.*, Figures 4.6 and 4.12) and mainly of *Subbotina* (Figures 3.12-3.13).

The eoglobigerinid spinose lineage is characterized by 3 ½ - 5 chambers in the first whorl (neanic stage). This character separates them from other pitted and cancellate Paleocene taxa such as *Globanomalina* or *Praemurica* (5 - 6 neanic chambers). This difference is similar to that which allowed Arenillas *et al.* (2007) to separate *Palaeoglobigerina* (3 ½ - 4 neanic chambers) from *Parvularugoglobigerina* (4 - 4 ½ chambers, or even 5 in the neanic stage). The most primitive specimens of *E. simplicissima* (*e.g.*, Figure 5.4) still exhibit 3 ½ - 4 neanic chambers, similar

to *Palaeoglobigerina* (Arenillas *et al.*, 2007). This ontogenetic trait newly suggests that the eoglobigerinids derived from *Palaeoglobigerina*, with only a slight increase in the number of chambers in the neanic stage. This character was retained in the eoglobigerinids with 3 ½ - 4 chambers in the last whorl, such as *E. microcellulosa* (*e.g.*, Figures 3.8-3.10) and *E. cf. trivialis* (*e.g.*, Figures 3.5-3.6), as well as in *Subbotina* species (*e.g.*, Figure 3.15).

By contrast, *E. fringa*, species of *Eoglobigerina* with more than 4 chambers in the last whorl (*E. eobulloides*, *E. praeedita*, and *E. edita*) and *Parasubbotina* usually have 4 - 5 neanic chambers. Examples of this feature can be observed in Figures 2 and 4. We consider the *Parasubbotina* lineage (*E. fringa* - *Parasubbotina*) and the *E. edita* lineage (*E. eobulloides* - *praeedita* - *edita*) as two separate lineages with *E. simplicissima* as the common ancestor. They represent two evolutionary trends within Eoglobigerinidae: the first one towards the migration of the aperture in the umbilical-extraumbilical position and a lower trochospire, and the second one towards raising of the trochospire, the increase in the number of chambers and consequently a slower rate in increase of the chamber size.

Some primitive specimens of *E. simplicissima* (*e.g.*, Figure 5.5) also occasionally exhibit 4 - 5 neanic chambers, suggesting that this character was not very stable among the earliest eoglobigerinids. These *E. simplicissima* specimens could in fact be intermediate forms to *E. eobulloides* and even to *E. cf. trivialis*, which also exhibit this feature in some specimens (*e.g.*, Figures 3.7).

According to these data, we suggest that four eoglobigerinid lineages emerged from *E. simplicissima* (Figure 11). The oldest one is the *E. eobulloides* - *E. praeedita* - *E. edita* lineage, which culminates with eoglobigerinids with more than four chambers in the final whorl (Figure 7). This evolutionary series was also suggested by both Olsson *et al.* (1992, 1999) and Apellániz *et al.* (2002). The second one to occur was the lineage that culminated with *Parasubbotina*, *i.e.*, the evolution from *E. fringa* to *P. moskvini* (see Figure 8), and then to *P. pseudobulloides* and *P. varianta*. Intermediate specimens between *P. moskvini* and *P. pseudobulloides* (*e.g.*, Figure 8.5) and between *P. moskvini* and *P. varianta* (*e.g.*, Figure 4.6) are also found. A similar proposal was made by Apellániz *et al.* (2002) who also suggested *E. fringa* as the ancestral form of *Parasubbotina*. Olsson *et al.* (1999) concluded that *P. aff. pseudobulloides* was the ancestral form of this genus. This is consistent with our proposal since they assigned primitive, non-cancellate *P. moskvini* and *P. pseudobulloides* to their *P. aff. pseudobulloides* (see comments above). The third lineage to appear led to the genus *Subbotina* (see Figure 9) by the evolution from *E. microcellulosa* to *S. triloculinoides*. Due to different taxonomic interpretations, Olsson *et al.* (1999) proposed *E. trivialis* as ancestor of *Subbotina* while Apellániz *et al.* (2002) suggested *E. appressa* Blow (1979). However, all the latest hypotheses suggest that *Subbotina* evolved from *Eoglobigerina*. Finally, the fourth lineage

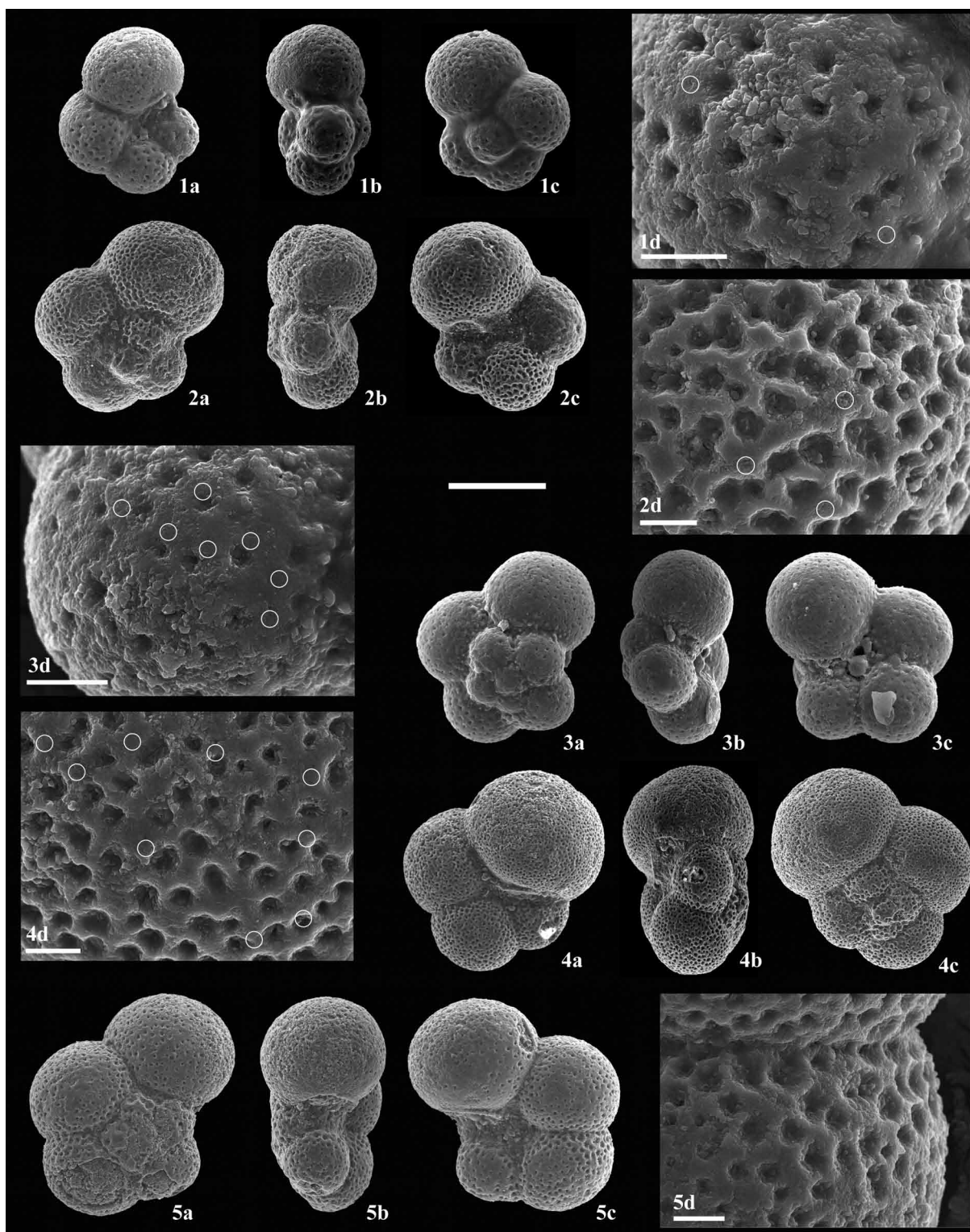

Figure 8. SEM images of *Eoglobigerina fringa* and *Parasubbotina moskvini* specimens and details of their smooth wall texture; probable spine holes surrounded with white circles (scale bar = 100 μm ; scale bar of wall details = 10 μm). 1-3. *Eoglobigerina fringa* (Subbotina, 1950): 1, juvenil specimen transitional to *P. moskvini*, from the *E. simplicissima* Subzone, El Kef, Tunisia; 2, specimen transitional to *P. moskvini*, from the *E. simplicissima* Subzone, El Kef, Tunisia; 3, specimen transitional to *P. moskvini*, from the *E. simplicissima* Subzone, El Kef, Tunisia. 4-5. *Parasubbotina moskvini* (Shutskaya, 1953): 4, specimen from the *E. simplicissima* Subzone, El Kef, Tunisia; 5, specimen transitional to *P. pseudobulloides*, from the *E. simplicissima* Subzone, El Kef, Tunisia. Solid circles mark probable or certain spine holes.

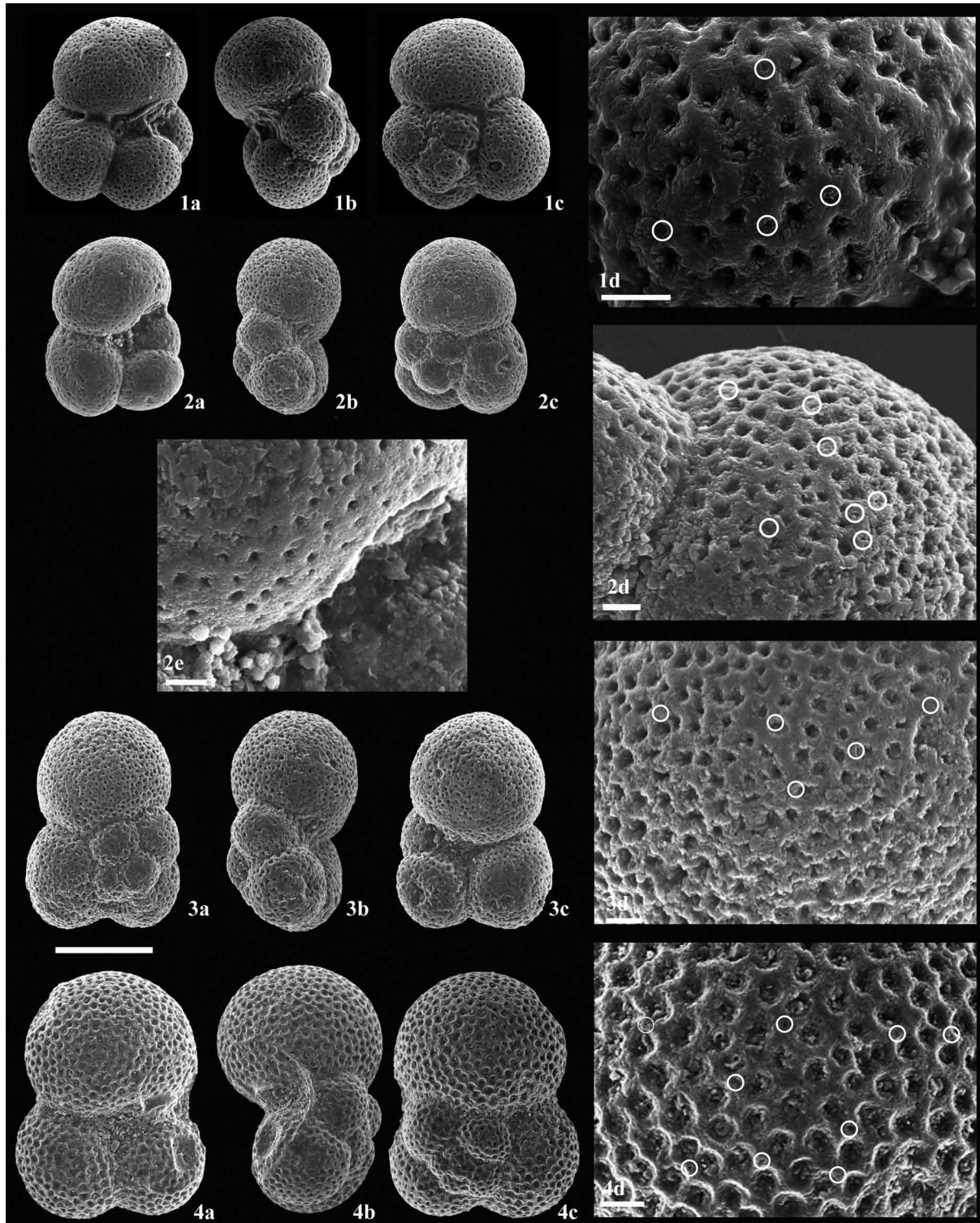

Figure 9. SEM images of *Eoglobigerina simplicissima*, *Eoglobigerina microcellulosa* and *Subbotina triloculinoidea* specimens and details of their smooth wall texture; possible spine holes surrounded with white circles (scale bar = 100 μ m; scale bar of wall details = 10 μ m). 1. *Eoglobigerina simplicissima* Blow (1979): specimen from the *E. simplicissima* Subzone, El Kef, Tunisia. 2-3. *Eoglobigerina microcellulosa* (Morozova, 1961): 2, specimen from the *E. simplicissima* Subzone, El Kef, Tunisia; 3, specimen from the *E. simplicissima* Subzone, El Kef, Tunisia. 4. *Subbotina triloculinoidea* (Plummer, 1927): specimen from the *S. triloculinoidea* Subzone, Ben Gurion, Israel. Solid circles mark probable or certain spine holes.

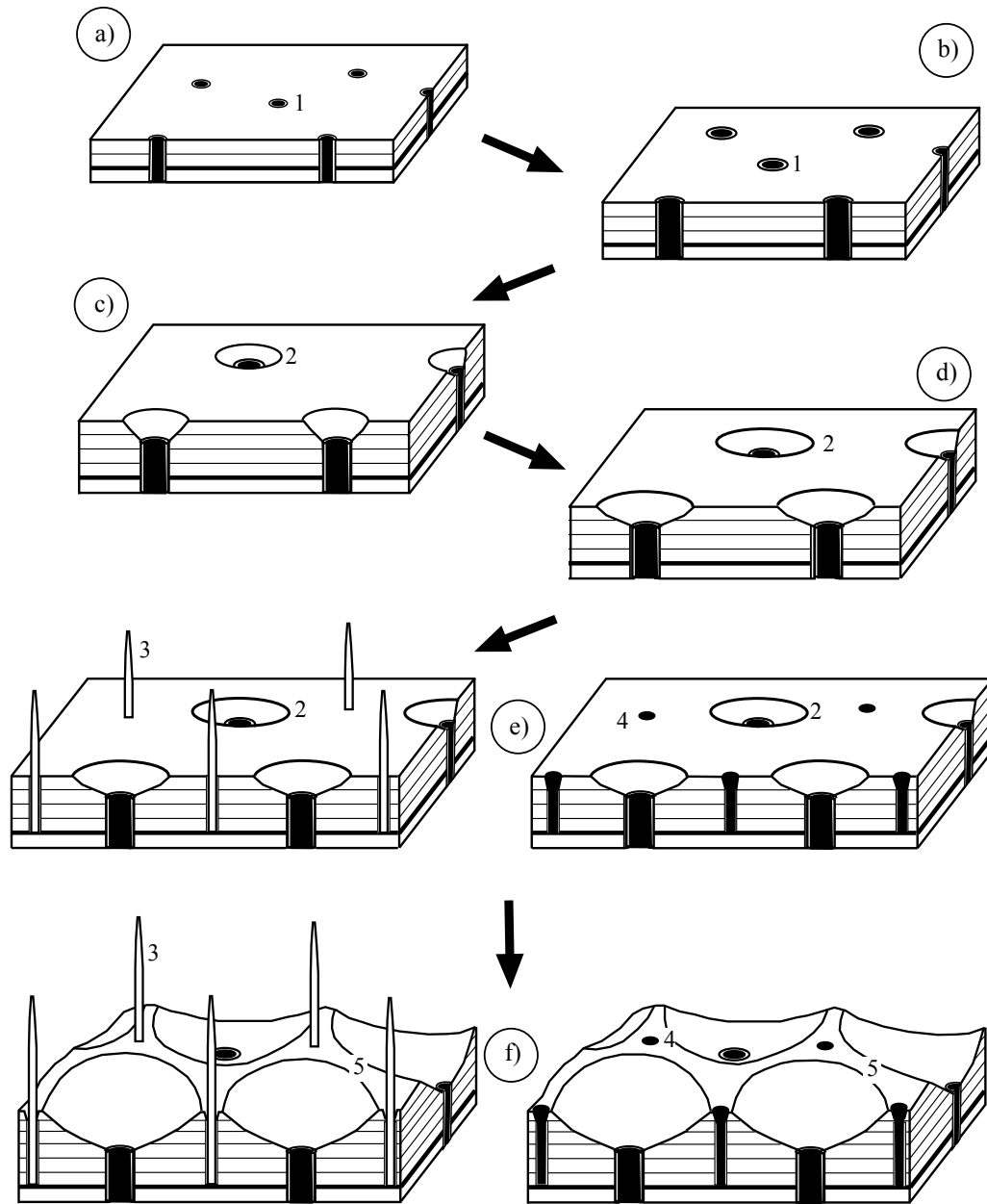

Figure 10. Diagrams of the wall textures and their hypothetic evolution from the smooth wall of *Palaeoglobigerina* to the spinose and cancellate walls of *Eoglobigerinidae*: (a), smooth wall texture with tiny mural pores in typical *Palaeoglobigerina*; (b), smooth wall texture with larger pore-murals in evolved *Palaeoglobigerina*; (c), nonspiny, pitted wall texture with small pore-pits (in *Palaeoglobigerina* transitional to *Eoglobigerina*); (d), nonspiny, pitted wall texture with larger pore-pits (in primitive *Eoglobigerina*); (e), spinose, pitted wall texture (in primitive *Eoglobigerina-Parasubbotina*); (f), spinose, cancellate wall texture (in typical *Eoglobigerina*, *Parasubbotina* and *Subbotina*). In (e) and (f), diagrams to the left with preserved spines, to the right with dissolved spines leaving vacated spine holes. Textural elements: (1), mural pores; (2), pore-pits; (3), spines; (4), spine holes; (5) interpore ridges.

started with *E. cf. trivialis*. The evolutionary relationships of this lineage, which tended towards the raising of the trochospire (culminating with *E. tetragona* Morozova, 1961, in lower-middle Danian), are not so clear at the present state of knowledge. Probably *E. cf. trivialis* and *E. eobulloides* share *E. simplicissima* as common ancestor, because, as mentioned above, they all present 4 - 5 neanic chambers occasionally.

CONCLUSIONS

An intensive search of transitional specimens, mainly from the lower Danian El Kef and Aïn Settara sections, has allowed us to find new evidence on the origin and early diversification of the Family Eoglobigerinidae, which groups together spinose and cancellate genera of the early Paleocene (e.g. *Eoglobigerina*,

Parasubbotina and *Subbotina*). Our data suggest an evolution from *Palaeoglobigerina* to *Eoglobigerina*, and then in separate branches to *Parasubbotina* and to *Subbotina*.

The transition between *Palaeoglobigerina* and *Eoglobigerina* implied an increase of the test size, the pore diameter and the thickness of the lip, as well as the development of pore-pits, spines and, finally, cancellate walls. At least four lineages derived from *E. simplicissima*:

- (1) *Parasubbotina* Lineage (*E. fringa*, *P. moskvini*, *P. varianta*, *P. pseudobulloides*) tending towards the migration of the aperture into an umbilical-extraumbilical position, and a lower trochospire;
- (2) *Subbotina* Lineage (*E. microcellulosa*, *S. triloculinooides*), tending towards a decrease in the number of chambers and a higher rate of increase in the chamber size;
- (3) *E. edita* Lineage (*E. eobulloides*, *E. praeedita*, *E. edita*), tending towards the trochospire raise, the increase in the number of chambers and a lower rate of chamber size increase;
- (4) *E. cf. trivialis* Lineage, tending towards the trochospire raise.

ACKNOWLEDGMENTS

We thank Hanspeter Luterbacher, and an anonymous reviewer for helpful comments. We also thank Carolina Nández for the review of the manuscript. This research was funded by the Spanish Ministerio de Ciencia e Innovación projects CGL2011-23077 and CGL2011-22912 (both co-financed by the European Regional Development Fund), and the Aragonian Departamento de Educación y Ciencia (DGA group E05). Authors would like to acknowledge the use of Servicio General de Apoyo a la Investigación-SAI, Universidad de Zaragoza. The authors are grateful to Richard Stephenson for English corrections.

APPENDIX 1

Geographical coordinates of the stratigraphic sections mentioned in MATERIAL AND METHODS:

Tunisia: El Kef (latitude 36°8'45" N, longitude 8°38'48" E), Aïn Settara (latitude 36°46'44" N, longitude 8°29'53" W), and Elles (latitude 35°56'40" N, longitude 9°4'59" E).

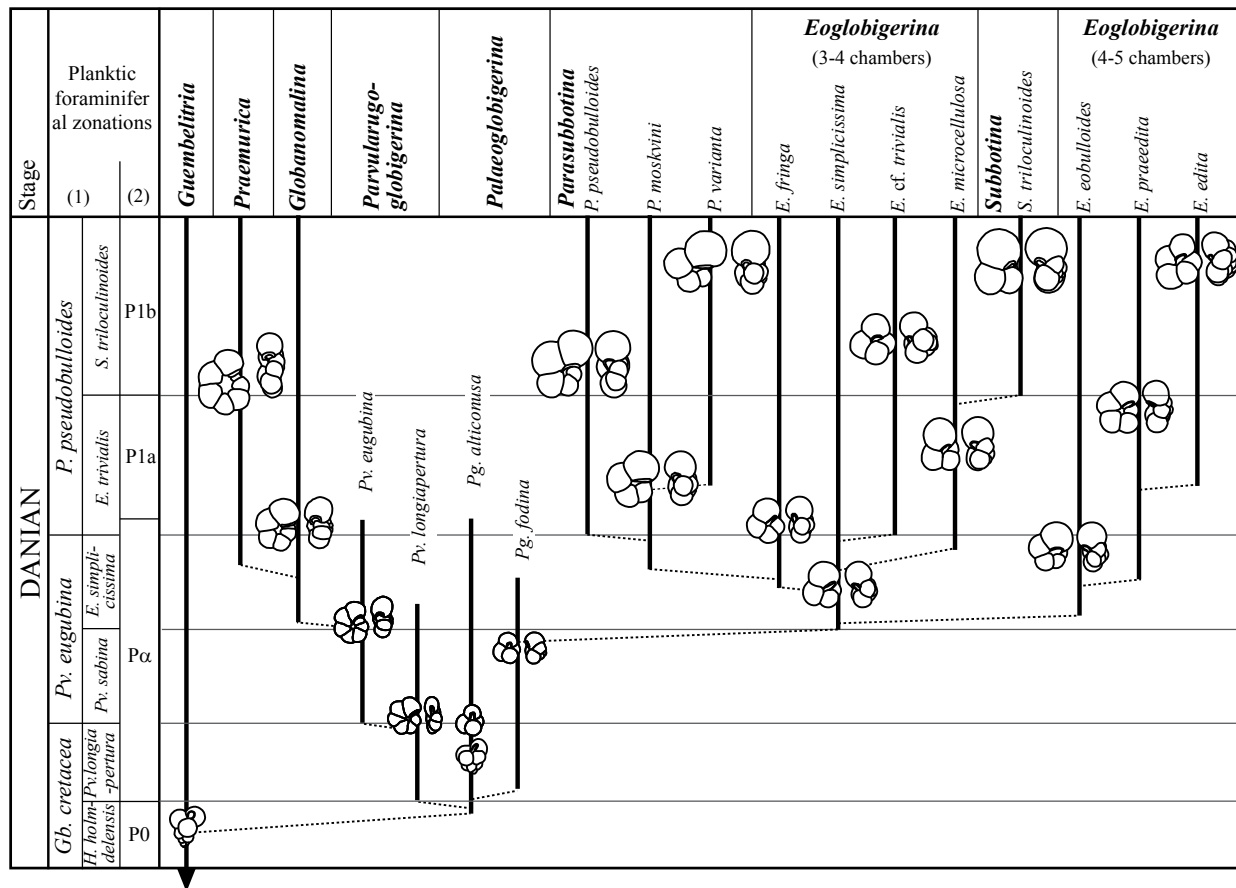

Figure 11. Proposed phylogenetic relationship of the lineage *Guembeltria* Cushman (1933) - *Palaeoglobigerina* Arenillas, Arz and Nández (2007) - *Parvularugoglobigerina* Hofker (1978) - *Globanomalina* Haque (1956) - *Praemurica* Olsson, Hemleben, Berggren and Liu (1992) are based on Arenillas et al. (2007, 2010).

Spain: Caravaca (latitude 39°5'19" N, longitude 1°52'26" W), Agost (latitude 38°27'80" N, longitude 0°38'11" W), Zumaia (latitude 43°17'56" N, longitude 2°16'4" W), Osinaga (latitude 42°54'6" N, longitude 1°44'36" W) and San Sebastián (latitude 43°18'47" N, longitude 2°0'42" W)

France: Bidart (latitude 43°26'54" N, longitude 1°35'16" W)

Italy: Gubbio (latitude 43°21'57" N, longitude 12°34'57" E)

Israel: Ben Gurion (latitude 30°50'54" N, longitude 34°45'37" E)

Mexico: El Mulato (latitude 24°53'3" N, longitude 98°56'30" W), El Mimbral (latitude 23°12'40" N, longitude 98°40'30" W), La Lajilla (latitude 23°39'21" N, longitude 98°44'3" W), Bochil (latitude 17°0'43" N, longitude 92°56'50" W) and Guayal (latitude 17°32'39" N, longitude 92°36'80" W)

Cuba: Loma Capiro (latitude 22°24'35" N, longitude 79°56'77" W)

USA (Mississippi): Lynn Creek (latitude 33°12'1", longitude 88°43'47")

Argentina: Bajada del Jagüel (latitude 38°6'11" S, longitude 68°23'19" W)

North Pacific: DSDP Site 305 (latitude 32°0'21" N, longitude 157°51'0" E).

APPENDIX 2

Taxonomic list and diagnostic characters of the lower Danian species of *Palaeoglobigerina* Arenillas, Arz and Nández (2007), *Eoglobigerina* Morozova (1959), *Parasubbotina* Olsson, Berggren and Liu (1992) and *Subbotina* Brotzen and Pozaryska (1961) mentioned in the text:

Palaeoglobigerina alticonusa (Li, McGowran and Boersma, 1995): Small trochospiral test, with high spire, 3 ½ - 4 spherical chambers in the first whorl, 3 ½ - 4 subglobular chambers in the last whorl, low to moderate rate of chamber size increase, aperture intraumbilical, high arch, lip thin, wall surface smooth or secondarily granular (Figures 2.1-2.2).

Palaeoglobigerina fodina (Blow, 1979): Small trochospiral test, with low spire, 3 ½ - 4 spherical chambers in the first whorl, 3 ½ - 4 subglobular chambers in the last whorl, low to moderate rate of chamber size increase, aperture intraumbilical, usually high arch, lip thin, wall surface smooth or secondarily granular (Figures 2.3-2.5; Figures 5.1-5.3).

Eoglobigerina simplicissima Blow (1979): Trochospiral test, with low spire, 3 ½ - 4 spherical chambers in the first whorl, 3 ½ - 4 subglobular chambers in the last whorl, low to moderate rate of chamber size increase, aperture intraumbilical, lip moderately thick, wall surface weakly cancellate, spinose (Figures 2.6-2.9; Figures 5.4-5.5;

Figures 6.1-6.3; Figure 7.5; Figures 9.1).

Eoglobigerina fringa (Subbotina, 1950): Trochospiral test, with low spire, 3 ½ - 4 spherical chambers in the first whorl, 4 subglobular chambers in the last whorl, low to moderate rate of chamber size increase, aperture umbilical to somewhat extraumbilical, lip moderately thick, wall surface cancellate weakly developed, spinose (Figures 4.1-4.3; Figures 6.4-6.5; Figures 8.1-8.3).

Eoglobigerina eobulloides Morozova (1959): Trochospiral test, with low spire, 4 - 5 spherical chambers in the first whorl, 4 - 4 ½ subglobular chambers in the last whorl, low rate of chamber size increase, aperture umbilical to somewhat extraumbilical, lip moderately thick, wall surface cancellate, spinose (Figures 2.10-2.13; Figures 7.1-7.3).

Eoglobigerina praeedita Blow (1979): Trochospiral test, with low spire, 4 ½ - 5 spherical chambers in the first whorl, 4 ½ - 5 subglobular chambers in the last whorl, low rate of chamber size increase, aperture umbilical to somewhat extraumbilical, lip moderately thick, wall surface cancellate, spinose (Figures 2.14-16; Figure 7.4).

Eoglobigerina edita (Subbotina, 1953): Trochospiral test, with slightly raised spire, 4 ½ - 5 spherical chambers in the first whorl, 4 ½ - 5 subglobular chambers in the last whorl, low rate of chamber size increase, aperture umbilical to somewhat extraumbilical, lip moderately thick, wall surface cancellate, spinose (Figures 2.17-2.20).

Eoglobigerina microcellulosa (Morozova, 1961): Trochospiral test, with low spire, 3 ½ - 4 spherical chambers in the first whorl, 3 ½ subglobular chambers in the last whorl, moderate rate of size increase, aperture umbilical to somewhat extraumbilical, lip moderately thick, wall surface cancellate weakly developed, spinose (Figures 3.8-3.10; Figures 9.2-9.3).

Eoglobigerina cf. *trivialis* (*E. trivialis* Subbotina, 1953, *sensu* Blow, 1979): Trochospiral test, with lightly high spire, 3 ½ - 4 ½ subglobular chambers in the first whorl, 3 ½ - 4 spherical chambers in the last whorl, low to moderate rate of chamber size increase, aperture intraumbilical, lip moderately thick, wall surface cancellate, spinose (Figures 3.1-3.7).

Parasubbotina moskvini (Shutsкая, 1953): Trochospiral test, with low spire, 4 spherical chambers in the first whorl, 4 subglobular chambers in the last spiral whorl, moderate rate of chamber size increase, aperture umbilical-extraumbilical, lip moderately thick, wall surface cancellate, spinose (Figures 4.4-4.6; Figures 8.4-8.5).

Parasubbotina pseudobulloides (Plummer, 1927): Trochospiral test, with low spire, 4 ½ - 5 spherical chambers in the first whorl, 4 ½ - 5 subglobular chambers in the last spiral whorl, moderate rate of chamber size increase, aperture umbilical-extraumbilical, lip moderately thick, wall surface cancellate, spinose (Figures 4.10-4.12).

Parasubbotina varianta (Subbotina, 1953), Trochospiral test, with low spire, 4 - 4 ½ spherical chambers in the first whorl, 4 subglobular chambers in the last whorl, high rate of chamber size increase, aperture umbilical-

extraumbilical, lip moderately thick, wall surface cancellate, spinose (Figures 4.7-4.9).

Subbotina triloculinoidea (Plummer, 1927): Trochospiral test, with low spire, 3 ½ - 4 spherical chambers in the first whorl, 3 - 3 ½ subglobular chambers in the last whorl, moderate to high rate of chamber size increase, aperture umbilical to somewhat extraumbilical, lip thick, wall surface cancellate, spinose (Figures 3.11-3.15; Figure 9.4).

REFERENCES

- Apellániz, E., Orue-Etxebarria, X., Luterbacher H.P., 2002, Evolution of the early Paleocene planktonic foraminifera: a Basque point of view: *Neues Jahrbuch für Geologie and Paläontologie, Abhandlungen*, 225, 157-194.
- Arenillas, I., 1996, Los foraminíferos planctónicos del Paleoceno-Eoceno inferior: Sistemática, Bioestratigrafía, Cronoestratigrafía y Paleocanografía: Zaragoza, España, *Prensas Universitarias de Zaragoza*, 2000, 513 pp.
- Arenillas, I., Arz, J.A., 1996, Origen y filogenia de las primeras especies de foraminíferos planctónicos del Paleoceno basal, tras el límite Cretácico/Terciario, in *Perejón, A., Comas, M.J., Costa, M., García-Mas, I., Gomis, A., Moreno, M. y Outeruelo, R. (eds.), XII Bienal, Tomo extraordinario del 125 Aniversario de la Real Sociedad Española de Historia Natural, Madrid, España*, 267-271.
- Arenillas, I., Arz, J.A., 2000, *Parvularugoglobigerina eugubina* type-sample at Ceselli (Italy): planktic foraminiferal assemblage and lowermost Danian biostratigraphic implications: *Rivista Italiana di Paleontologia e Stratigrafia*, 106, 379-390.
- Arenillas, I., Arz, J.A., Molina, E., Dupuis, C., 2000a, An independent test of planktic foraminiferal turnover across the Cretaceous/Paleogene (K/P) boundary at El Kef, Tunisia: Catastrophic mass extinction and possible survivorship: *Micropaleontology*, 46, 31-49.
- Arenillas, I., Arz, J.A., Molina, E., Dupuis, C., 2000b, The Cretaceous/Paleogene (K/P) boundary at Ain Settara, Tunisia: sudden catastrophic mass extinction in planktic foraminifera: *Journal of Foraminiferal Research*, 30, 202-218.
- Arenillas, I., Arz, J.A., Molina, E., 2004, A new high-resolution planktic foraminiferal zonation and subzonation for the lower Danian: *Lethaia*, 37, 79-95.
- Arenillas, I., Arz, J.A., Nájuez, C., 2007, Morfología, Biometría y Taxonomía de foraminíferos planctónicos del Daniense basal: *Palaeoglobigerina* n. gen.: *Revista Española de Paleontología*, 22, 21-62.
- Arenillas, I., Arz, J.A., Nájuez, C., 2010, Diversidad y evolución de la textura de la pared en guembelítridos (foraminíferos planctónicos) en el tránsito Cretácico-Paleógeno: *Revista Española de Paleontología*, 25, 87-105.
- Arenillas, I., Arz, J.A., Nájuez, C., 2012, Smooth and rugose wall textures in earliest Danian trochospiral planktic foraminifera from Tunisia: *Neues Jahrbuch für Geologie und Paläontologie, Abhandlungen*, 266, 123-142.
- Berggren, W.A., 1962, Some planktonic foraminifera from the Maestrichtian and type Danian stages of Southern Scandinavia: *Stockholm Contributions in Geology*, 9, 1-18.
- Berggren, W.A., 1977, Atlas of Paleogene Planktonic Foraminifera. Some species of the genera *Subbotina*, *Planorotalites*, *Morozovella*, *Acarinina* and *Truncorotaloides*, in *Ramsay, A.T.S. (ed.), Oceanic Micropaleontology*: Academic Press, London, 250-299.
- Berggren, W.A., Pearson, P.N., 2005, A revised tropical to subtropical Paleogene planktonic foraminiferal zonation: *Journal of Foraminiferal Research*, 35, 279-298.
- Blow, W.H., 1979, The Cainozoic Globigerinidae. A study of the morphology, taxonomy, evolutionary relationship and the stratigraphical distribution of some Globigerinidae (mainly Globigerinacea): Leiden, Netherlands, E.J. Brill, 3 vols. +1413 pp.
- Bolli, H.M., 1951, The genus *Globotruncana* in Trinidad, B.W.I.; Notes on occurrence, nomenclature and relationships between species: *Journal of Paleontology*, 25, 187-199.
- Bolli, H.M., 1957, The genera *Globigerina* and *Globorotalia* in the Paleocene-lower Eocene Lizard Springs formation of Trinidad, B.W.I.: *United States National Museum Bulletin*, 215, 97-124.
- Bolli, H.M., Loeblich, A.R. Jr., Tappan, H., 1957, Planktonic foraminiferal families Hantkeninidae, Orbulinidae, Globorotaliidae and Globotruncanidae: *United States National Museum Bulletin*, 215, 3-50.
- Brönnimann, P., Brown, N.K.Jr., 1958, *Hedbergella*, a new name for a Cretaceous planktonic foraminiferal genus: *Journal of the Washington Academy of Sciences*, 48, 15-17.
- Brotzen, F., Pozaryska, T., 1961, Foraminifères du Paléocène et de l'Éocène inférieur en Pologne septentrionale; remarques paléogéographiques: *Revue de Micropaléontologie*, 4, 155-166.
- Canudo J.I., Keller G., Molina E., 1991, Cretaceous foraminiferal extinction pattern and faunal turnover at Agost and Caravaca, SE Spain: *Marine Micropaleontology*, 17, 319-341.
- Carpenter, W.B., Parker, W.K., Jones, T.R., 1862, Introduction to the study of the Foraminifera: London, Ray Society and R. Hardwicke, 22, 319 pp.
- Cushman, J.A., 1933, Some New Foraminiferal Genera: Contributions from the Cushman Laboratory for Foraminiferal Research, 9, 32-38.
- Haque, A.F.M.M., 1956, The smaller Foraminifera of the Ranikot and the Laki of the Nammal Gorge, Salt Range: *Paleontologica Pakistanica, Geological Survey of Pakistan*, 1, 1-300.
- Hemleben C., Mühlen, D., Olsson R.K., Berggren W.A., 1991, Surface texture and the first occurrence of spines in planktonic foraminifera from the early Tertiary: *Geologische Jahrbuch*, 128, 117-146.
- Hofker, J., 1978, Analysis of a large succession of samples through the Upper Maastrichtian and the Lower Tertiary of Drill Hole 47.2, Shatsky Rise, Pacific, Deep Sea Drilling Project: *Journal of Foraminiferal Research*, 8, 46-75.
- Jenkins, D.G., 1971, New Zealand Planktonic Foraminifera: *New Zealand Geological Survey, Paleontological Bulletin*, Wellington, 42, 1-278.
- Keller, G., 1988, Extinction, survivorship and evolution of planktic foraminifera across the Cretaceous/Tertiary boundary at El Kef, Tunisia: *Marine Micropaleontology*, 13, 239-263.
- Keller, G., Li, L., MacLeod, N., 1995, The Cretaceous/Tertiary boundary stratotype sections at El Kef, Tunisia: How catastrophic was the mass extinction?: *Palaeogeography, Palaeoclimatology, Palaeoecology*, 119, 221-254.
- Khalilov, D.M., 1956, O pelagicheskoy faune foraminifer Paleogenovykh otlozheniy Azerbaydzana: *Trudy Instituta Geologii, Akademiyi Nauk Azerbaydzhanskoy S.S.R., Baku*, 17, 234-261.
- Liu, C., Olsson R.K., 1992, Evolutionary radiation of microporate planktonic foraminifera following the K/T mass extinction event: *Journal of Foraminiferal Research*, 22, 328-346.
- Liu, C., Olsson R.K., 1994, On the origin of Danian normal perforate planktonic foraminifera from *Hedbergella*: *Journal of Foraminiferal Research*, 24, 61-74.
- Li, Q., McGowran B., Boersma A., 1995, Early Paleocene *Parvularugoglobigerina* and late Eocene *Praetenuitella*: does evolutionary convergence imply similar habitat?: *Journal of Micropaleontology*, 14, 119-134.
- Loeblich, A.R.Jr., Tappan, H., 1957, Planktonic foraminifera of Paleocene and early Eocene age from the Gulf and Atlantic coastal plains: *United States National Museum Bulletin*, 215, 173-197.
- Loeblich, A.R.Jr., Tappan, H., 1987, Foraminiferal genera and their classification: New York, Van Nostrand Reinhold Company, Vol. 2, 970 pp.
- Luterbacher, H.P., Premoli-Silva, I., 1964, Biostratigrafía del límite Cretaceo-Terciario nell' Appennino Centrale: *Rivista Italiana di Paleontologia e Stratigrafia*, 70, 67-128.
- Molina, E., Alegret, L., Arenillas, I., Arz, J.A., Gallala, N., Hardenbol, J., von Salis, K., Steurbaut, E., Vandenberghe, N., Zaghib-Turki, D., 2006, The Global Stratotype Section and Point of the Danian Stage (Paleocene, Paleogene, "Tertiary", Cenozoic) at El Kef,

- Tunisia: original definition and revision: *Episodes*, 29, 263-278.
- Molina, E., Alegret, L., Arenillas, I., Arz, J.A., Gallala, N., Grajales-Nishimura, J.M., Murillo-Muñetón, G. and Zaghbib-Turki, D. 2009, The Global Boundary Stratotype Section and Point for the base of the Danian Stage (Paleocene, Paleogene, "Tertiary", Cenozoic): auxiliary sections and correlation: *Episodes*, 32, 84-95.
- Montanaro-Gallitelli, E., 1957, A revision of the foraminiferal Family Heterohelicidae: *Studies in Foraminifera*, United States National Museum Bulletin, 215, 133-154.
- Morozova, V.G., 1959, Stratigrafiya Datsko-Montskikh otlozhenii Kryma po foraminiferam: *Doklady Akademii Nauk SSSR*, 124, 1113-1116.
- Morozova, V.G., 1961, Datsko-Montskikh planktonnye foraminifery yuga SSSR: *Paleontologicheskii Zhurnal*, 1, 8-19.
- Olsson, R.K., 1960, Foraminifera of latest Cretaceous and earliest Tertiary age in the New Jersey Coastal Plain: *Journal of Paleontology*, 34, 1-58.
- Olsson, R.K., 1963, Latest Cretaceous and earliest Tertiary stratigraphy of New Jersey Coastal Plain: *Bulletin of the American Association of Petroleum Geologists*, 47, 643-665.
- Olsson, R.K., 1970, Planktonic foraminifera from base of Tertiary Millers Ferry, Alabama: *Journal of Paleontology*, 44, 598-604.
- Olsson R.K., Hemleben C., Berggren W.A., Liu, C., 1992, Wall texture classification of planktonic foraminifera genera in the Lower Danian: *Journal of Foraminiferal Research*, 22, 195-213.
- Olsson R.K., Hemleben C., Berggren W.A., Huber B.T. 1999, Atlas of Paleocene Planktonic Foraminifera: *Smithsonian Contributions to Paleobiology*, 85, 1-252.
- Orue-Etxebarria, X., 1985, Descripción de *Globigerina hillebrandti* n. sp. en el límite Cretácico/Terciario de la sección de Sopelana (País Vasco). Evolución de los primeros planctónicos al comienzo de Terciario: *Newsletters on Stratigraphy*, 15, 71-78.
- Plummer, H.J., 1927, Foraminifera of the Midway formation in Texas: *Bulletin University of Texas Bureau of Economic Geology and Technology*, 2644, 1-206.
- Sexton, P.F., Wilson, P. A., Pearson, P.N., 2006, Microstructural and geochemical perspectives on planktic foraminiferal preservation: "Glassy" versus "Frosty": *Geochemistry, Geophysics, Geosystems*, 7, Q12P19.
- Shutskaya, E.K., 1953, Raschlenenie kubanskogo i elburganskogo gorizontov Severnogo Kavkaza po globigerinam: *Biulletin Moskovskogo Obschestva Ispytateley Prirody, Otdel Geologicheskii*, 28, 71-79.
- Smit, J., 1982, Extinction and evolution of planktonic foraminifera after a major impact at the Cretaceous/Tertiary boundary: *Geological Society of America Special Paper*, 190, 329-352.
- Stainforth, R.M., Lamb, J.L., Luterbacher, H.P., Beard, J.H., Jeffords, R.M., 1975, Cenozoic planktonic foraminiferal zonation and characteristics of index forms: *The University of Kansas Paleontological Contributions*, 62, 1-425.
- Subbotina, N.N., 1950, Mikrofauna i stratigrafiya Elburganskogo Gorizonta Goriatchego Klyitcha; *Mikrofauna SSSR Sbornik 4: Trudy Vsesoyuzhnogo Nauchno-Issledovatel'skogo Geologorazvedochnogo Institut (VNIGRI)*, 51, 5-112.
- Subbotina, N.N., 1953, Iskopaemye Foraminifery SSSR (Globigerinidy, Khantkeninidy i Globorotaliidy); *Mikrofauna SSSR Sbornik 6: Trudy Vsesoyuzhnogo Nauchno-Issledovatel'skogo Geologorazvedochnogo Institut (VNIGRI)*, 76, 1-296.
- Toumarkine, M., Luterbacher, H.P., 1985, Paleocene and Eocene planktic foraminifera, in Bolli, H.M., Saunders J.B., Perch-Nielsen, K., (eds.), *Plankton Stratigraphy*: Cambridge University Press, Cambridge, 88-153.

Manuscript received: July 23, 2012

Corrected manuscript received: November 9, 2012

Manuscript accepted: November 12, 2012